

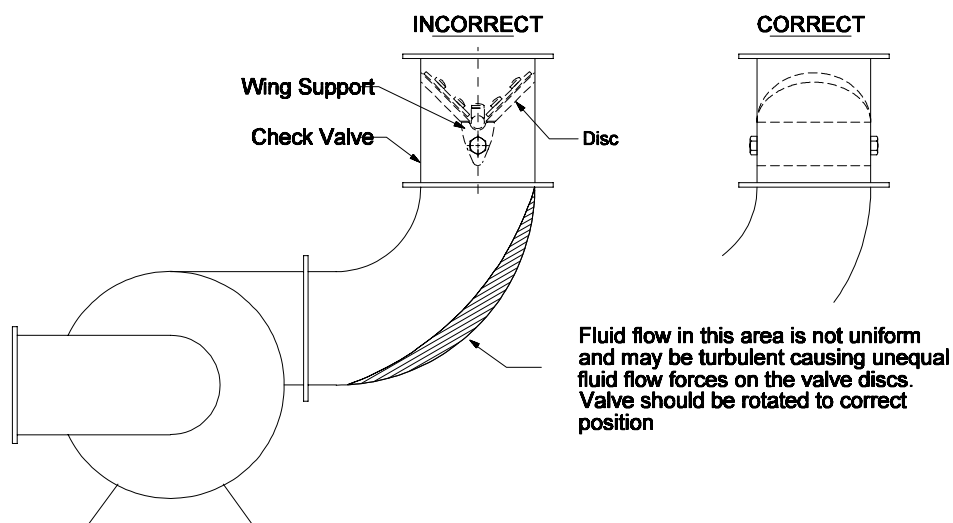

1. Remove check valve from packaging and inspect for any shipping damage or loose fasteners. All fasteners have been set with Loctite®. If damaged in shipping, save original box and box contents.
2. If check valve is to be painted or insulated, record the US Valve data on the valve identification tag.
3. If valves are being stored, they should be in a weather-protected area, preferably indoors.
4. Open and close the discs of your valve a few times by hand to assure freedom of movement.
5. **The flow arrow** on your valve indicates the direction of flow upon installation.
6. Use only a **strap type wrench** for installation to prevent distortion of the valve body.
7. The check valve is **not suitable for use on a discharge** of reciprocating or positive displacement compressors or pumps. Pulsating and cyclic flow will damage the valve.
8. **If this valve is installed in a horizontal line**, make sure the screws protruding through the top and bottom of the valve body are in the vertical position. Maintain at least 6 pipe diameters of straight length of piping between the check valve and any other line restriction, i.e. elbows, tees, valves, etc.
9. **If the valve installation is in a vertical line with upward flow**, the position of the wing support is not important. There should be at least 6 pipe diameters of straight unrestricted piping upstream and downstream of the check valve. If space conditions do not allow for this, the valve must be installed so that the flow is equally distributed across the two valve discs (see figure A below).

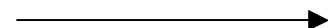

(Figure A)



PARTS REPLACEMENT INSTRUCTIONS



COMPLETE REPLACEMENT OF VALVE INTERNALS:

1. Carefully remove valve from pipeline. **USE ONLY A STRAP TYPE WRENCH.**
2. Hold the valve body in your hand or in a suitable vise to prevent distortion of the valve body.
NOTE: DO NOT EXERT UNDO FORCE ON THE VALVE BODY. This may permanently effect the valve operation.
3. Remove all valve internals by unscrewing the Wing Support screws (see *Figure 1 below*) and any other body support rods such as travel stop rods (only on large size valves).

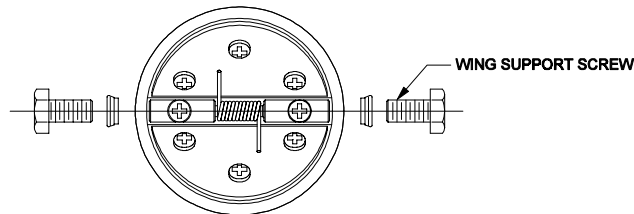
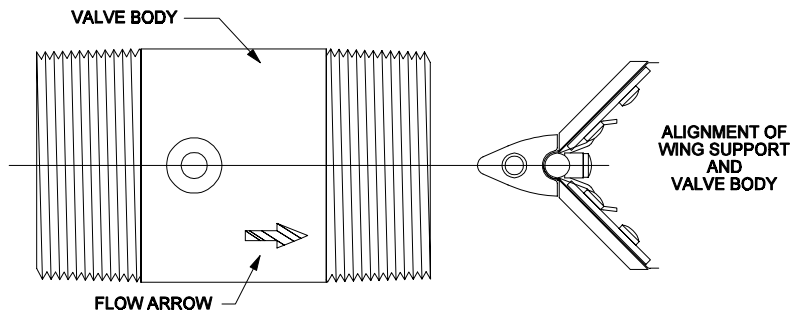

FIGURE 1

4. Inspect the body inside diameter to determine if the body is suitable and retains its original integrity i.e. surface finish is good and roundness apparent.
5. If valve body appears satisfactory and needs only minor cleanup, the valve is then suitable to replace the internals. **DO NOT SANDBLAST OR OTHERWISE DAMAGE THE VALVE BODY'S INNER SURFACE.**
6. Make sure when you order complete internal replacement assemblies that the new assemblies are identical to the original internals. Always reference your check valve's unique serial number when ordering replacements.
7. **Install the new assembly:**
 - (a) Put some water on the elastomer seal to act as a lubricant when installing the new wing support assembly into the valve body.
 - (b) Make sure you assemble the wing assembly correctly with the direction of flow.
 - (c) Align the wing support mounting screw holes and the valve body screw holes properly. (See *Figure 2*).



(Figure 2)

- (d) Push wing support assembly into the valve body until the holes line up properly. If you overshoot the hole alignment by half the screw hole diameter, just push the wing support assembly completely through the valve body and repeat the procedure.
- (e) When installing the wing support mounting screws, make sure you install a new Nylite[®] pressure seal and apply a sufficient amount of Loctite[®] #242 to the screw threads. The wing support screws should be torqued to 8-ft-lbs for 1/4-20 screws and 48 in-lbs for 10-32 screws. Never over tighten screws.
- (f) Allow Loctite[®] to dry 20 minutes, full cure in 24 hours.